



# ePicker

PICKING UP WHERE OTHERS LEAVE OFF

# LITHIUM FORKLIFT

## EFLP30

**CAPACITY** 6000 lbs. up to 130" at 24"  
load center



### BATTERY

80v 410AH Li-Ion battery, capable of fast charging, without gassing or need for maintenance or eye wash stations.

### PERFORMANCE

#### TRAVEL

7.4 mph empty

6.8 mph loaded

#### TIRES

##### FRONT

28" x 9-15" solid pneumatic

##### REAR

6.50" x 10" solid pneumatic

### OPERATOR COMPARTMENT

Operator compartment is exceptionally spacious due to purpose-built design for an integrated lithium battery. Ergonomic controls are provided for lift, lower, tilt and sideshift, which are within easy reach of the operator. Visibility is excellent through the wide view mast. Power steering with assist knob, adjustable steering column & adjustable suspension seat ensures comfortable working position and reduced fatigue during operation. Large mirror and overhead guard mounted hand rail aids operator when driving the in the reverse direction of travel. LCD programmable display communicates travel speed, battery discharge information, hour meter, and fault codes.

### HYDRAULICS

Hydraulic lift and drive components are sealed against dirt and water protecting them from contamination. Optional 4th valve, with control and hosing is available to support two function attachments.

### ELECTRICAL

80v AC controller technology delivers high efficiency and performance while significantly reducing maintenance cost and extending vehicle service life.

Vehicle features weather resistant components and construction to facilitate limited use in outdoor environments.

Battery management system monitors lithium battery performance during operation and charging to help extend battery service life far longer than traditional lead acid industrial batteries.

### DRIVE UNIT AND BRAKES

AC Drive motor delivers smooth torque and speed performance matched to vehicle needs in real-time for peak efficiency and performance. Regenerative neutral braking extends duty-cycle. Vehicle's brakes and lever actuated parking brake ensure effective stopping power during operation and when on rated grades.

### FRAME AND MAST

Heavy duty steel chassis features long wheel-base, wide tires and low center of gravity for stable operation. Wide view mast includes an integral side-shift and load back rest (LBR). High seating position gives the operator an excellent view for efficient load handling at ground level and elevation. Integral sideshift as standard equipment. Triple stage wide view masts deliver maximum lift heights of up to 197".

### SERVICEABILITY

On-board programmable LCD display allows for troubleshooting and system adjustments without need of tools. Units come pre-wired for optional telematics system that includes cloud based maintenance monitoring, GPS tracking and related data services.

### STANDARD FEATURES

- Headlights and brake lights
- Turn signals & back up alarm
- Solid pneumatic tires
- Integral sideshift
- USB accessory charging port
- 480v three phase or 120v charger

### OPTIONAL EQUIPMENT

- 4 way hydraulics w/ no attachments
- 4 way hydraulics w/ hang on SS
- Side shifting fork positioner
- Blue light

### TELEMETRY

- Truck location in real-time
- Reports of truck usages and diagnosis
- Li-ion battery condition analytics

## DIMENSIONS

# LITHIUM FORKLIFT

EFLP30



### UL RATED LITHIUM SOLUTION: FAST CHARGE, CLEAN POWER, LOW COST

- 6-7 hour run time with up to 20% recharge in less than 30 minutes.
- No fumes, watering, or eye wash stations required
- Lowest operating cost of any general purpose forklift

### EFLP30 Rated Capacity

6000 lbs. up to 130" at 24" load center

**Gradeability:** 15% Loaded and Unloaded

5 YEAR  
10,000 HOUR

**LITHIUM  
BATTERY**  
WARRANTY

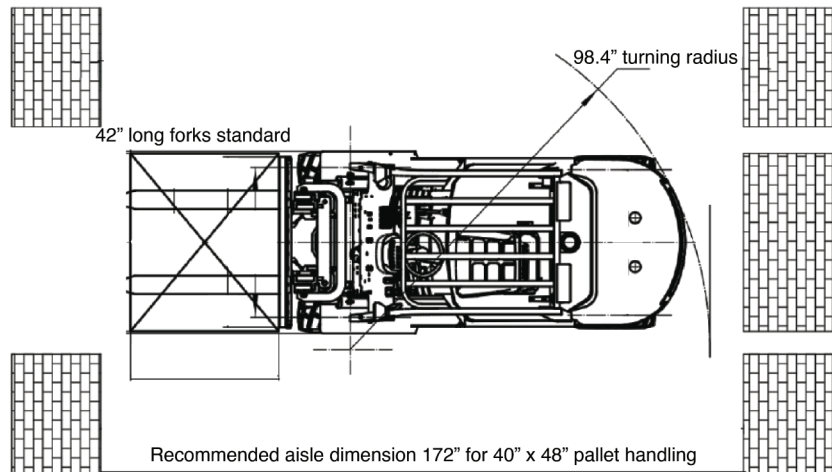
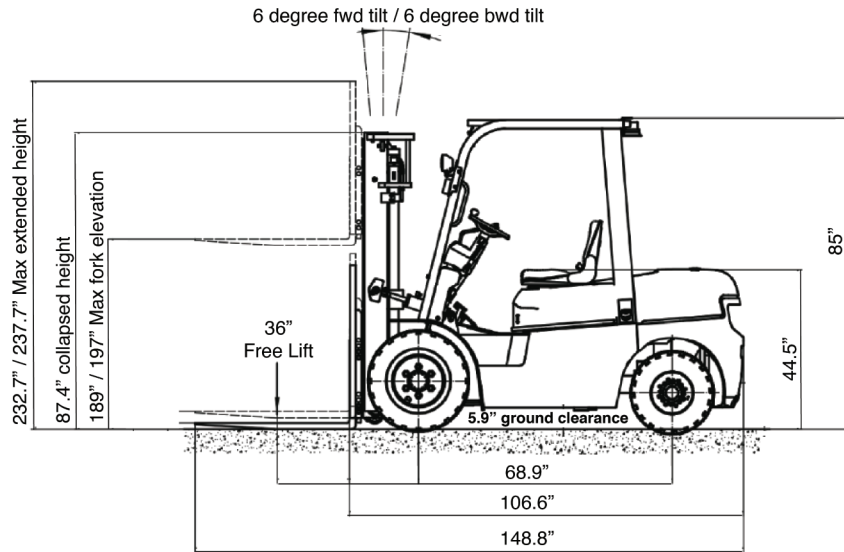

MODEL#	MAST	LIFT HEIGHT	COLUMN HEIGHT	FREE LIFT WITH BACKREST	EXTENDED HEIGHT WITH BACKREST	WEIGHT
		A	B	C	D	

**6,000 lbs. up to 130" at 24" load center**

EFLP30-189	Three Stage	189	87.4	36	232.7	10,428 lbs.
EFLP30-197	Three Stage	197	87.4	36	237.7	10,428 lbs.