

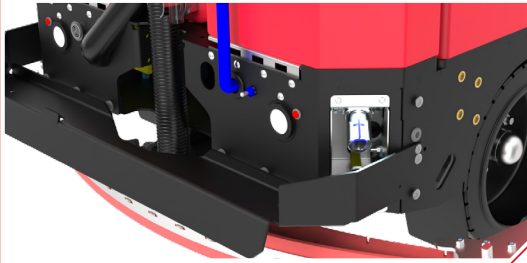

Key Features

Brake Lights, Rear Lights, Flip Up Bumper, and Service Cabinet



Your Choice Of Central Command

Military

Legacy

Touch



Wider Side Brooms, LED Headlights, 2nd Point Adjustable Wiper Blades.

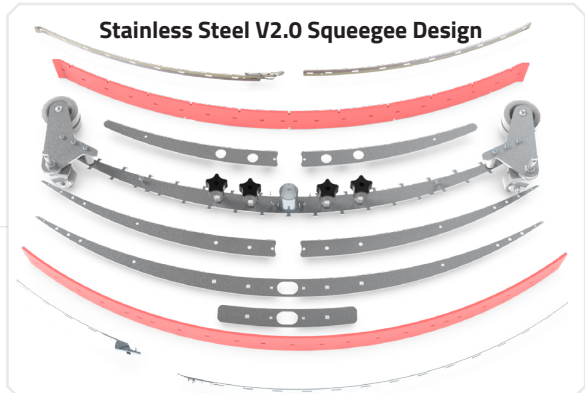
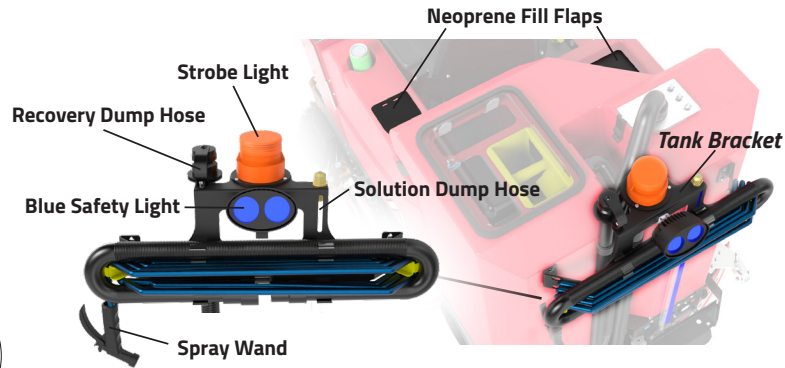
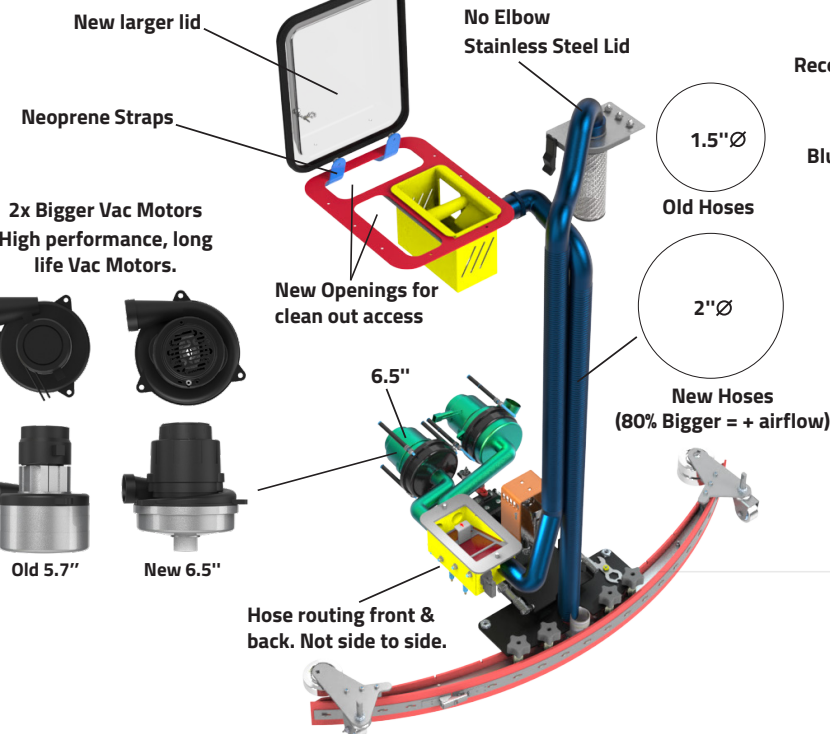

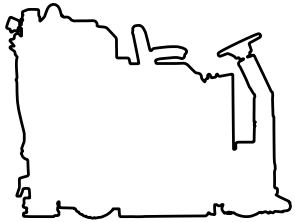

XR v2.0

Technical Specs

FACTORYCAT
Handmade in U.S.A. - Est 1986

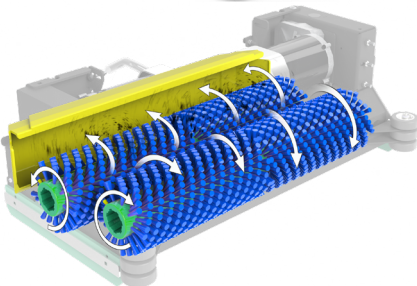

Cylindrical Benefits

- Eliminates Pre-Sweeping
- Scrub & Sweep Simultaneously
- Superior Tile & Grout Cleaning
- Great for Indoor Track Fields

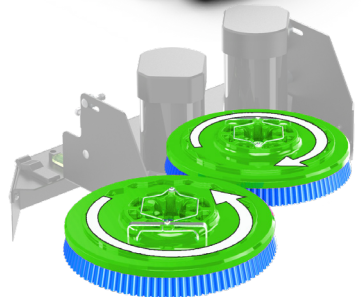

Disk Benefits

- Largest Brush/ Pad Selection
- Lowest Maintenance Cost
- Best Performance on Irregular Floors
- Brushes Individually driven

BODY CONSTRUCTION/ DIMENSIONS	
Chassis Construction:	3/16" Steel (4.8 mm) Powder Coated
Front Wheels (Ø x Width)	12" x 4" (30 x 10 cm) - Solid Black
Rear Wheels (Ø x Width):	(2x) 14" x 5" ([2x] 36 x 12 cm) - Solid Black
Size (L x W x H):	77" x 43" x 59" (177 x 93 x 144 cm)
Weight (w/o Batteries):	1,200 lbs - 1,250 lbs (544 - 567 kg)
Weight (w/ Batteries):	1,925 - 1,975 lbs (873 - 896 kg)
BRUSH / PAD SYSTEM	
Disk Dimensions:	40" - (2x) 20" Ø (101 - [2x] 50 cm) 45" - (2x) 23" Ø (114 - [2x] 58 cm)
Disk Motor:	(2x) 1.5 hp 350 rpm ([2x] 746 watts)
Disk Brush Speed:	350 rpm
Cylindrical Dimensions:	40" - (2x) 7" Ø x 38" (101 - [2x] 18 x 81 cm) 46" - (2x) 7" Ø x 44" (116 - [2x] 18 x 112 cm)
Cylindrical Motor:	(2x) 1.5 hp 350 rpm ([2x] 1,118 watts)
Cylindrical Brush Speed:	750 rpm
Brush Down Pressure:	Up to 300 lbs (113 kg) / 1200 lbs (227 kg) Actuator Rating
POWER SYSTEM	
System Voltage/Amps	36 VDC / 315 ah WET
Optional Battery:	Up to 425 ah WET / 400 ah AGM*
*Includes Onboard Charger	
Run Time:	Up to 5.0 Hours**
**Based on continuous scrubbing run times.	
DRIVE SYSTEM	
Power:	3.0 hp - All Gear / Sealed (2,237 watts)
Forward Speed:	0 - 320 ft/min / 0 - 3.6 mph (0 - 98 m/min / 0 - 6 km/h)
Scrubbing Speed:	0 - 256 ft/min / 0 - 2.9 mph (0 - 78 m/min / 0 - 5 km/h)
Reverse Speed:	0 - 230 ft/min / 0 - 2.6 mph (0 - 70 m/min / 0 - 4 km/h)
SOLUTION / RECOVERY SYSTEMS	
Solution Tank Capacity:	65 Gallons (246 liters) - w/ Graduated Site Tube
Solution Flow / Filter:	0 - 1.0 GPM / Stainless Inline (0 - 3.7 LPM)
Recovery Tank Capacity:	78 Gallons (295 liters) - 2" Ø Drain Hose
Demisting Chamber:	1.25 Gallons (4.7 liters)
Drain Saver:	30 cubic inches (2,130 cubic cm)
Vacuum Power (Water Lift / Airflow):	(2x) 1.0 hp / 2 Stage / 6.6" Ø (551watts) 73" / 96 cfm (186 cm / 2.7 cm/m)
GENERAL	
Decibels:	63 dBA / ECON 61 dBA**
**Decibel levels for Disk per ISO 11201 as recommended by the American Association of Cleaning Equipment Manufacturers & OSHA	
Productivity - Theoretical:	Up to 49,587 sqft/hr (4,607 sqm)***
***Based off of ISSA 2010 Cleaning Times	
Productivity - Practical:	Up to 22,989 sqft/hr (2,136 sqm)***
***Based off of ISSA 2010 Cleaning Times	