

MOVING YOU FURTHER

15.18
20BT-9U



Some of the photos may include optional equipment.



Your satisfaction is our priority!

Compact forklift with proven AC technology

Hyundai introduces the new BT-9U series 3 wheel battery forklift. The BT-9U series features upgrades to the previous series, including new technology that offers higher efficiency, durability and operator convenience.

Efficiency

- Application of Electric Power Steering System to improve energy efficiency
- Powerful and Sophisticated driving performance due to Dual Drive motors
- Light and Precise Fingertip control (OPT)
- Directional & Horn switch on lever (OPT)

Durability

- Application of ZF Drive System (Drive Axle + Drive motor) to improve reliability and durability of drive system
- Advanced reliability of information processing due to Dual micom - ZAPI controller
- Oil Cooled Wet Disc Brakes
- IP43 Motor & IP65 Controller

Safety

- Curve Control feature reduces driving speed when turning through a curve
- Anti-Roll Back feature prevents roll back on an incline
- Electric Auto Parking Brake
- Operator Presence Sensing System (OPSS)

Easy service

- Side Battery Extraction for easy change out
- Self Diagnostics function
- Continental SC18 Solid Tires for longer wear
- Brake fluid level sensing system





Power & Performance

High Efficiency & Optimal Performance

An efficient, smooth running and compact design provides enhanced performance and outstanding productivity.

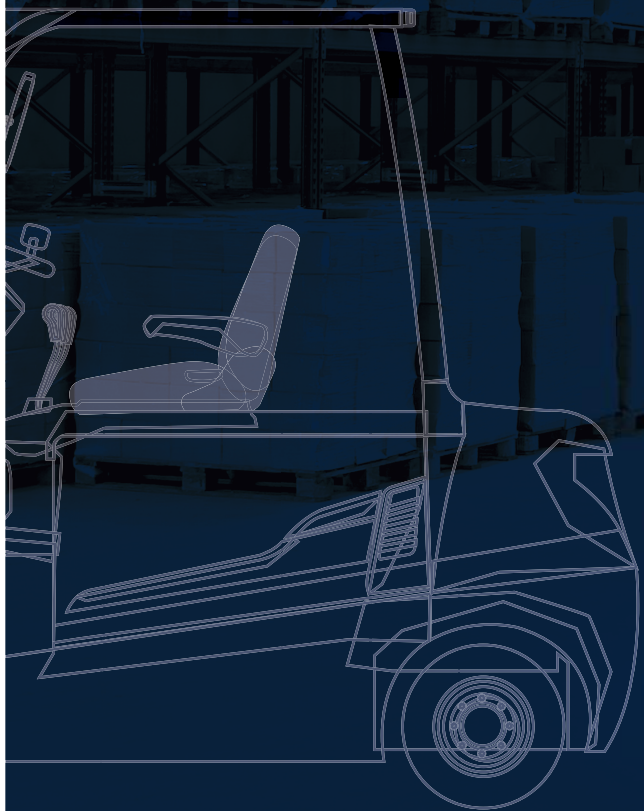

HIGH PERFORMANCE

Some of the photos may include optional equipment.

Applied ZF Drive Package (Drive Axle + Drive Motor + Electric Parking Brake) to Dual Drive system

UPGRADE

ZF is a top global power train manufacturer, known for reliability and durability. The ZF dual drive system ensures excellent drawbar pull and short turning radius, and brushless AC motors are virtually maintenance free. An automatic electric parking brake is also applied, which is safe and requires no physical operation.



Energy consumption Improvement

The energy consumption has been significantly reduced due to newly applied EPS (Electric Power Steering) system and ZF drive package.

This adoption is expected to decrease the costs and increase the operating time.

Previous Model (20BT-9 : 585Ah) : 251 minutes (100%)

Upgraded Model (20BT-9U : 585Ah) : 304 minutes (121%)

☒The figures above are based on Hyundai's test results for a single charge cycle and may differ from actual working conditions.

UPGRADE



EPS (Electric Power Steering) System

The EPS system consists of steering sensor, controller, and steering motor that operates only when steering wheel is turned. This design eliminates unnecessary energy consumption and noise.

UPGRADE



New ZAPI Controller

The new ZAPI AC controllers with dual micom monitor signals and detects faults making it is possible to control the forklift quickly and securely. Also, capacity of drive controller has been increased for driving performance.

UPGRADE



Auto fork leveling system (OPT)

In order to improve productivity the auto fork leveling system stops when the forks are level.



Continental SC18 Solid Tire

Continental SC18 solid tires are equipped as a standard. It ensures low energy consumption and long service life.



Vehicle Performance optimized for working condition

This function optimizes the performance of vehicle for the purpose of work, such as speed of operation, maximum working time and operator's proficiency.

H mode : High performance mode with fast driving speed and fast lifting speed

N mode : Normal mode with balanced performance and energy consumption

E mode : Economy mode maximizing battery life



Easy & Comfort

Optimized Ergonomics & Fast and Easy Maintenance

An ideal arrangement of components ensures easy access and convenience for maintenance.

COMFORTABLE WORKSPACE

ADVANCED MONITORING SYSTEM



Spacious operating space

The newly designed operating space was made for more space, a wider field of view and operator comfort.



Some of the photos may include optional equipment.



Comfortable suspension seat

An adjustable ergonomic seat provides unmatched comfort. The adjustable armrest further reduces operator fatigue.

- Adjustable suspension stiffness based on the driver's weight (99~375lbs/45~170kg)
- ELR type seat belt standard
- Heater and Backrest extension (OPT)



Directional & horn switch on lever (OPT)

Electronic directional control and secondary horn are mounted to the hydraulic lift lever for quick and precise maneuvering.



Finger tip control levers (OPT)

Ergonomically designed fingertip control levers for improved operator comfort and productivity. The armrest can be adjusted for operator comfort.

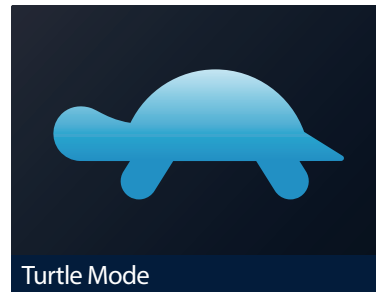

Turtle Mode

When selecting the turtle mode while working in narrow and congested workplace, the travel speed is reduced at a preset speed.

4.3 inch LCD color monitor

The LCD color monitor with 4.3 inch graphic smart display allows the operator to identify speed, travel direction, and operating hours and control the machine efficiently. The load indicator displays the load weight in the monitor. The operator can select various performance modes to meet all working conditions. Multilanguage (maximum 11) is available.

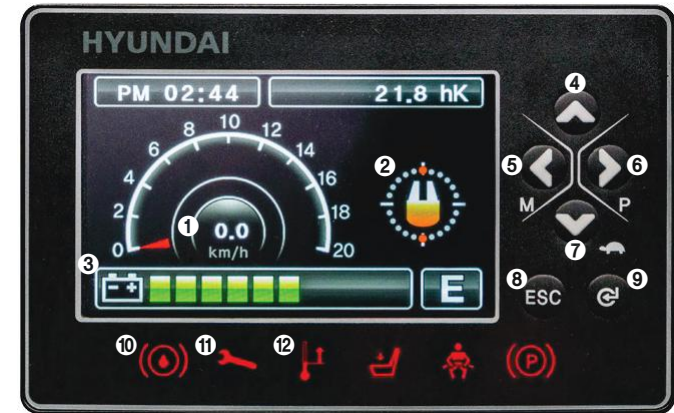

Advanced LCD Monitor

- | | |
|--|------------------------------|
| ① Speed (Digital) | ⑦ Turtle/Scroll down |
| ② Steering wheel position and travel direction | ⑧ ESC/Back |
| ③ Battery discharge indicator | ⑨ Enter |
| ④ Scroll up | ⑩ Low brake oil warning lamp |
| ⑤ Menu/Scroll Left | ⑪ Error warning lamp |
| ⑥ Performance/Scroll right | ⑫ High temp warning lamp |



Easy battery replacement

Guide bar installed on the wall helps the battery to be moved to the right position smoothly when removing and mounting.



Brake oil reservoir with level sensor

The enhanced brake oil reservoir, located in the upper left dash is equipped with an electronic level sensor and easily visible through the monitor.



Secure & Safety

Advanced Safety

Ergonomically designed compartment for operator's safety and comfort.

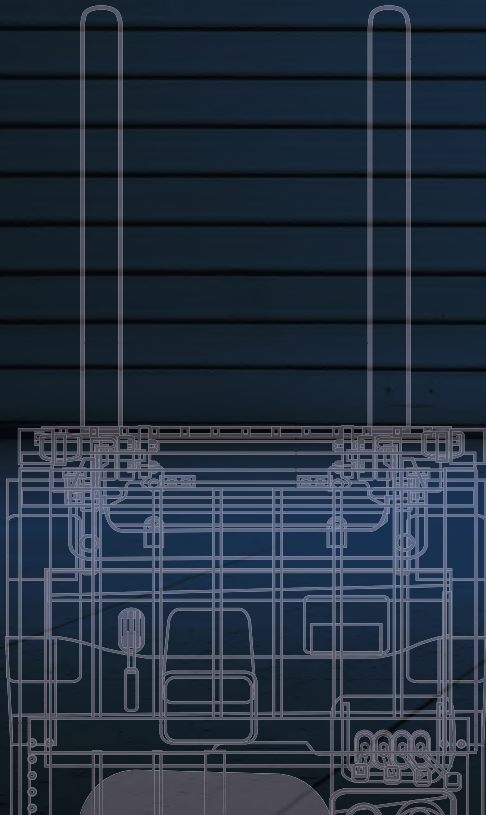

EXCELLENT VISIBILITY



ADVANCED SAFETY



You can see the video by scanning the QR code.

Some of the photos may include optional equipment.

Excellent visibility for safe operation

Optimized lift cylinder arrangement provides the operator with wider visibility.
The panoramic mirror expands the driver's view when backing up.



Some of the photos may include optional equipment.



Strong overhead guard

Exceeding ISO6055 regulations, the overhead guard offers great protection combined with excellent all around visibility.



Safety lamps

LED headlights and LED combination lights enhance the drivers visibility in all conditions.



Auto parking brake

Parking brake automatically applies when operator leaves the seat and when switch is turned off.

Safety features

The adoption of a high-sensitivity sensor and advanced safety system can prevent the safety accidents.

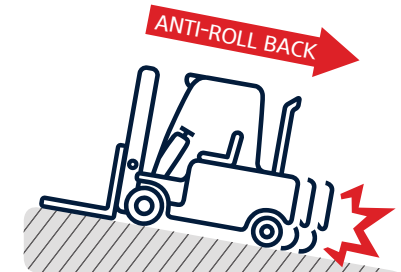

Anti roll back system

Anti Roll-back system offers protection against the machine rolling back on a ramp in combination with exceptional ramp start capabilities.

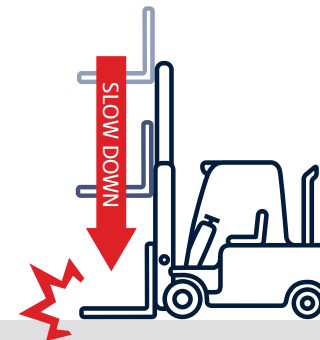

Fork safety features

As the forks are being lowered, a down-control valve maintains a controlled descent speed. The down-safety valve prevents forks from dropping down in case of sudden damage of hydraulic line.



Operator Presence Sensing System (OPSS)

When operator is not in seat the hydraulic lift and tilt controls and travel are locked out.

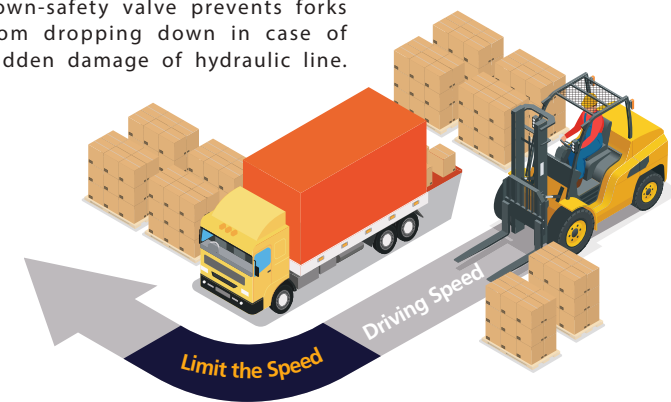

Curve control

Curve Control limits travel speed based on turning radius for a smooth, precise turning operation for the driver.

New 9 Series Mast Specification

15/18/20BT-9U

15BT-9U



Mast Type	Maximum Fork Height		Overall Height (Lowered)		Free lift height						Tilt Angle		Load capacity w/o side shift		Load capacity w/side shift		Truck Weight (Unloaded)		
					With Load Backrest		Without Load Backrest		Without Load Backrest (3/4-SPOOL)		Fwd	Bwd	24 in LC	500 mm LC	24 in LC	500 mm LC			
	in	mm	in	mm	in	mm	in	mm	in	mm	deg	deg	lb	kg	lb	kg	lb	kg	
2-STAGE LIMITED FREE LIFT	V270	107.5	2730	71.7	1822							5	7	3000	1500	2930	1440	6841	3103
	V300	119.3	3030	77.6	1972							5	7	3000	1500	2930	1440	6885	3123
	*V330	131.1	3330	83.5	2122							5	7	3000	1500	2930	1440	6929	3143
	V350	139.0	3530	87.5	2222	1.4	35	1.4	35	1.4	35	5	7	3000	1500	2930	1440	6958	3156
	V370	146.9	3730	91.4	2322							5	7	3000	1500	2930	1440	6986	3169
	V400	158.7	4030	97.3	2472							5	7	2950	1450	2840	1400	7039	3193
	V450	178.3	4530	111.1	2822							5	5	2840	1400	2730	1340	7189	3261
	V500	198.0	5030	120.9	3072							5	5	2750	1350	2640	1300	7262	3294
2-STAGE FULL FREE LIFT	VS300	119.3	3030	77.6	1972	38.3	972	59.3	1507	51.6	1312	5	5	3000	1500	2930	1440	6969	3161
	VS330	131.1	3330	83.5	2122	44.2	1122	59.3	1507	51.6	1312	5	5	3000	1500	2930	1440	7017	3183
3-STAGE FULL FREE LIFT	TF370	147.2	3740	69.8	1772	30.4	772	47.0	1205	42.0	1065	5	5	3000	1475	2860	1420	7138	3238
	TF400	159.1	4040	73.7	1872	34.3	872	51.3	1305	45.8	1165	5	5	2930	1450	2820	1390	7183	3258
	TF430	170.9	4340	77.6	1972	38.3	972	55.3	1405	49.8	1265	5	5	2840	1400	2730	1340	7227	3278
	TF450	178.7	4540	81.6	2072	42.2	1072	61.2	1555	55.7	1415	5	5	2800	1375	2680	1320	7269	3297
	TF470	186.6	4740	83.5	2122	44.2	1122	61.2	1555	55.7	1415	5	5	2750	1350	2640	1300	7293	3308
	TF500	198.4	5040	87.5	2222	48.1	1222	59.6	1515	59.6	1515	5	5	2640	1300	2550	1250	7337	3328
	TF550	218.1	5540	95.4	2422	56.0	1422	75.0	1905	69.5	1765	5	5	2550	1250	2460	1200	7423	3367
	TF600	237.8	6040	103.2	2622	63.9	1622	82.8	2105	77.3	1965	5	5	2420	1175	2310	1130	7564	3431
	TF650	257.5	6540	111.1	2822	71.7	1822	89.9	2285	84.5	2145	3	3	1850	900	1760	850	7663	3476
	TF700	277.2	7040	119.0	3022	79.6	2022	97.0	2465	91.5	2325	3	3	1340	650	1270	610	7747	3514
	TS430	170.9	4340	77.6	1972	38.3	972	51.4	1307	44.8	1137	5	5	2840	1400	2730	1340	7227	3278
	TS450	178.7	4540	81.6	2072	42.2	1072	57.3	1457	50.6	1287	5	5	2800	1375	2680	1320	7269	3297
	TS470	186.6	4740	83.5	2122	44.2	1122	57.3	1457	50.6	1287	5	5	2750	1350	2640	1300	7293	3308
	TS500	198.4	5040	87.5	2222	48.1	1222	61.3	1557	54.6	1387	5	5	2640	1300	2550	1250	7337	3328
	TS550	218.1	5540	95.4	2422	56.0	1422	71.1	1807	64.5	1637	5	5	2550	1250	2460	1200	7423	3367
	TS600	237.8	6040	103.2	2622	63.9	1622	79.0	2007	72.3	1837	5	5	2420	1175	2310	1130	7564	3431
TS650	257.5	6540	111.1	2822	71.7	1822	86.0	2187	79.4	2017	3	3	1850	900	1760	850	7663	3476	
TS700	277.2	7040	119.0	3022	79.6	2022	93.0	2367	86.5	2197	3	3	1340	650	1270	610	7747	3514	

☒TS-Mast : Wide Visible 3-Stage Full Free Lift Mast with 2 Free Lift Cylinders.

※ : Standard

18BT-9U



Mast Type	Maximum Fork Height		Overall Height (Lowered)		Free lift height						Tilt Angle		Load capacity w/o side shift		Load capacity w/side shift		Truck Weight (Unloaded)		
					With Load Backrest		Without Load Backrest		Without Load Backrest (3/4-SPOOL)		Fwd	Bwd	24 in LC	500 mm LC	24 in LC	500 mm LC			
	in	mm	in	mm	in	mm	in	mm	in	mm	deg	deg	lb	kg	lb	kg	lb	kg	
2-STAGE LIMITED FREE LIFT	V270	107.5	2730	71.8	1824							5	7	3500	1800	3500	1730	7467	3387
	V300	119.3	3030	77.7	1974							5	7	3500	1800	3500	1730	7509	3406
	*V330	131.1	3330	83.6	2124							5	7	3500	1800	3500	1730	7555	3427
	V350	139.0	3530	87.6	2224	1.4	35	1.4	35	1.4	35	5	7	3500	1800	3500	1730	7584	3440
	V370	146.9	3730	91.5	2324							5	7	3500	1800	3500	1730	7610	3452
	V400	158.7	4030	97.4	2474							5	7	3500	1750	3410	1680	7665	3477
	V450	178.3	4530	111.2	2824							5	5	3460	1700	3350	1640	7813	3544
	V500	198.0	5030	121.0	3074							5	5	3280	1600	3150	1540	7888	3578
2-STAGE FULL FREE LIFT	VS300	119.3	3030	77.7	1974	38.6	981	58.2	1479	52.7	1339	5	5	3500	1800	3500	1730	7595	3445
	VS330	131.1	3330	83.6	2124	44.5	1131	58.2	1479	58.6	1489	5	5	3500	1800	3500	1730	7641	3466
3-STAGE FULL FREE LIFT	TF370	147.2	3740	69.8	1774	30.7	781	47.4	1205	41.9	1065	5	5	3500	1750	3410	1680	7765	3522
	TF400	159.1	4040	73.8	1874	34.7	881	47.4	1205	45.9	1165	5	5	3460	1700	3320	1630	7809	3542
	TF430	170.9	4340	77.7	1974	38.6	981	47.4	1205	49.8	1265	5	5	3370	1650	3260	1590	7853	3562
	TF450	178.7	4540	81.7	2074	42.6	1081	61.2	1555	55.7	1415	5	5	3320	1625	3190	1560	7895	3581
	TF470	186.6	4740	83.6	2124	44.5	1131	61.2	1555	55.7	1415	5	5	3260	1600	3130	1530	7919	3592
	TF500	198.4	5040	87.6	2224	48.5	1231	65.2	1655	59.6	1515	5	5	3170	1550	3060	1490	7963	3612
	TF550	218.1	5540	95.4	2424	56.3	1431	75.0	1905	69.5	1765	5	5	2970	1450	2860	1390	8049	3651
	TF600	237.8	6040	103.3	2624	64.2	1631	82.9	2105	77.4	1965	5	5	2420	1175	2310	1130	8190	3715
	TF650	257.5	6540	111.2	2824	72.1	1831	90.0	2285	84.4	2145	3	3	2180	1050	2090	1010	8287	3759
	TF700	277.2	7040	119.1	3024	80.0	2031	98.4	2499	92.9	2359	3	3	1670	800	1580	760	8373	3798
	TS430	170.9	4340	77.7	1974	38.6	981	51.5	1307	44.8	1137	5	5	3370	1650	3260	1590	7853	3562
	TS450	178.7	4540	81.7	2074	42.6	1081	57.4	1457	50.7	1287	5	5	3320	1625	3190	1560	7895	3581
	TS470	186.6	4740	83.6	2124	44.5	1131	57.4	1457	50.7	1287	5	5	3260	1600	3130	1530	7919	3592
	TS500	198.4	5040	87.6	2224	48.5	1231	61.3	1557	54.6	1387	5	5	3170	1550	3060	1490	7963	3612
	TS550	218.1	5540	95.4	2424	56.3	1431	71.1	1807	64.4	1637	5	5	2970	1450	2860	1390	8049	3651
	TS600	237.8	6040	103.3	2624	64.2	1631	79.0	2007	72.3	1837	5	5	2420	1175	2310	1130	8190	3715
TS650	257.5	6540	111.2	2824	72.1	1831	86.1	2187	79.4	2017	3	3	2180	1050	2090	1010	8287	3759	
TS700	277.2	7040	119.1	3024	80.0	2031	93.2	2367	86.5	2197	3	3	1670	800	1580	760	8373	3798	

☒TS-Mast : Wide Visible 3-Stage Full Free Lift Mast with 2 Free Lift Cylinders.

※ : Standard

20BT-9U



Mast Type	Maximum Fork Height		Overall Height (Lowered)		Free lift height						Tilt Angle		Load capacity w/o side shift		Load capacity w/side shift		Truck Weight (Unloaded)		
	in	mm	in	mm	With Load Backrest		Without Load Backrest		Without Load Backrest (3/4-SPOOL)		Fwd deg	Bwd deg	24 in LC lb	500 mm LC kg	24 in LC lb	500 mm LC kg			
					in	mm	in	mm	in	mm									
2-STAGE LIMITED FREE LIFT	V270	107.5	2730	71.8	1824							5	7	4000	2000	3900	1920	7762	3521
	V300	119.3	3030	77.7	1974							5	7	4000	2000	3900	1920	7804	3540
	*V330	131.1	3330	83.6	2124							5	7	4000	2000	3900	1920	7851	3561
	V350	139.0	3530	87.6	2224	1.6	40	1.6	40	1.6	40	5	7	4000	2000	3900	1920	7879	3574
	V370	146.9	3730	91.5	2324							5	7	4000	2000	3900	1920	7906	3586
	V400	158.7	4030	97.4	2474							5	7	3960	1950	3810	1880	7961	3611
	V450	178.3	4530	111.2	2824							5	5	3770	1850	3630	1780	8108	3678
	V500	198.0	5030	121.0	3074							5	5	3660	1800	3540	1730	8183	3712
2-STAGE FULL FREE LIFT	VS300	119.3	3030	77.7	1974	38.8	986	59.7	1516	52.9	1344	5	5	4000	2000	3900	1920	7890	3579
	VS330	131.1	3330	83.6	2124	44.7	1136	59.7	1516	58.8	1494	5	5	4000	2000	3900	1920	7937	3600
3-STAGE FULL FREE LIFT	TF370	147.2	3740	69.8	1774	30.9	786	47.6	1210	42.1	1070	5	5	3960	1950	3830	1880	8060	3656
	TF400	159.1	4040	73.8	1874	34.9	886	51.6	1310	46.1	1170	5	5	3880	1900	3720	1830	8104	3676
	TF430	170.9	4340	77.7	1974	38.8	986	55.5	1410	50.0	1270	5	5	3770	1850	3660	1790	8148	3696
	TF450	178.7	4540	81.7	2074	42.8	1086	61.4	1560	55.9	1420	5	5	3720	1825	3590	1770	8190	3715
	TF470	186.6	4740	83.6	2124	44.7	1136	61.4	1560	55.9	1420	5	5	3680	1800	3540	1740	8214	3726
	TF500	198.4	5040	87.6	2224	48.7	1236	65.4	1660	59.8	1520	5	5	3570	1750	3460	1690	8258	3746
	TF550	218.1	5540	95.4	2424	56.5	1436	75.2	1910	69.7	1770	5	5	3480	1700	3370	1640	8344	3785
	TF600	237.8	6040	103.3	2624	64.4	1636	83.1	2110	77.6	1970	5	5	3200	1550	3080	1500	8485	3849
	TF650	257.5	6540	111.2	2824	72.3	1836	90.2	2290	84.6	2150	3	3	2645	1200	2535	1150	8582	3893
	TF700	277.2	7040	119.1	3024	80.2	2036	98.6	2504	93.1	2364	3	3	2180	1050	2110	1010	8668	3932
	TS430	170.9	4340	77.7	1974	38.8	986	51.7	1312	45.0	1142	5	5	3770	1850	3660	1790	8148	3696
	TS450	178.7	4540	81.7	2074	42.8	1086	57.6	1462	50.9	1292	5	5	3720	1825	3590	1770	8190	3715
	TS470	186.6	4740	83.6	2124	44.7	1136	57.6	1462	50.9	1292	5	5	3680	1800	3540	1740	8214	3726
	TS500	198.4	5040	87.6	2224	48.7	1236	61.5	1562	54.8	1392	5	5	3570	1750	3460	1690	8258	3746
	TS550	218.1	5540	95.4	2424	56.5	1436	71.3	1812	64.6	1642	5	5	3480	1700	3370	1640	8344	3785
	TS600	237.8	6040	103.3	2624	64.4	1636	79.2	2012	72.5	1842	5	5	3200	1550	3080	1500	8485	3849
TS650	257.5	6540	111.2	2824	72.3	1836	86.3	2192	79.6	2022	3	3	2645	1200	2535	1150	8582	3893	
TS700	277.2	7040	119.1	3024	80.2	2036	93.4	2372	86.7	2202	3	3	2180	1050	2110	1010	8668	3932	

※TS-Mast : Wide Visible 3-Stage Full Free Lift Mast with 2 Free Lift Cylinders.

※ : Standard

New 9 Series

15/18/20BT-9U

Load Capacity

15BT-9U

18BT-9U

20BT-9U

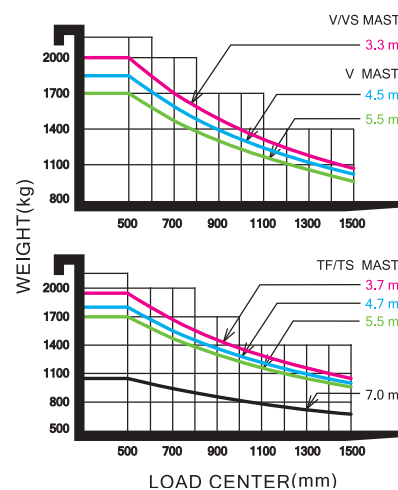
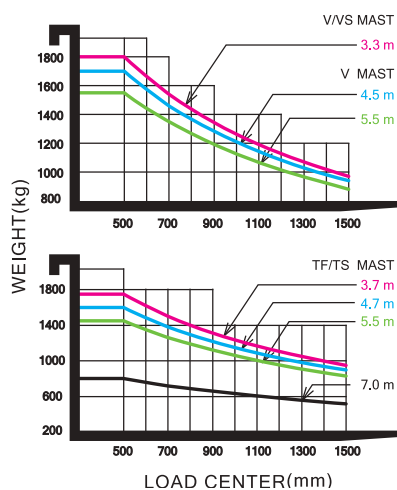
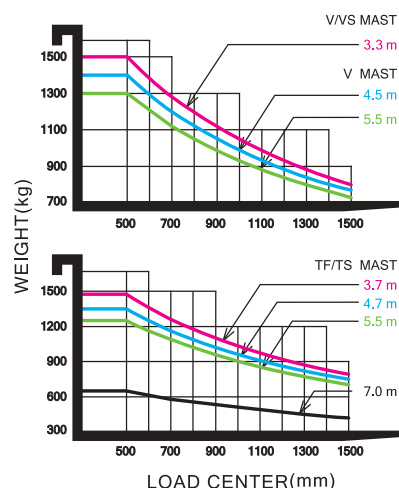

Various Attachments

Side Shift

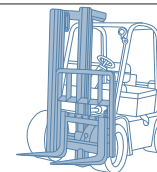

Hinged Fork

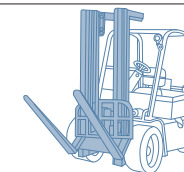

Hinged Bucket

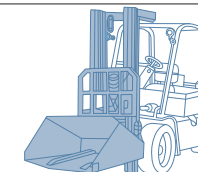

Rotating Fork

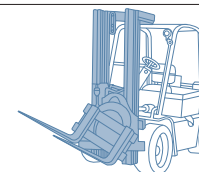

Push Pull

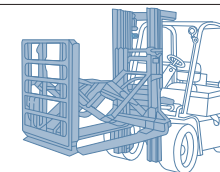

Rotating Roll Clamp

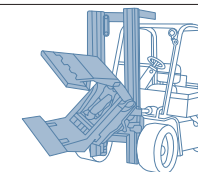

Load Stabilizer

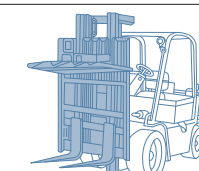

Carton Clamp

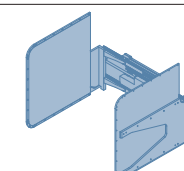

Pallet Invert

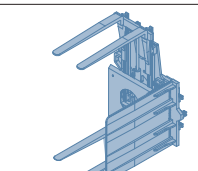

Drum Clamp

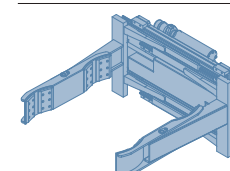

Bale Clamp

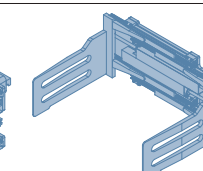

Load Extender

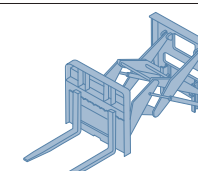

Fork Positioner

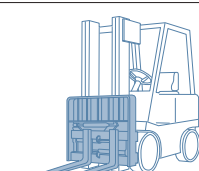

Optional Items

- Fork (mm) : 40x100x900(STD), 950, 1000, 1050, 1150, 1200, 1350, 1500, 1600
- Integral Sideshift · Finger Tip Control · Direction Switch on Lever
- Tire : Non-marking / Wide tire [15BT-9U : Front tire (200 / 50-10)] · Cold Storage (for - 30°C cold working environments)
- M.C.V : 2-Spool , 3-Spool(STD), 4-Spool · Auto Fork Leveling · Beacon Lam · Work lamp : LED
- UL : ES, EE · Cabin

Specification

DISTINGUISHING MARK					
1.1	Manufacturer (Abbreviation)		Hyundai		
1.2	Manufacturer's Type Designation	15BT-9U	18BT-9U	20BT-9U	
1.3	Drive : Electric (Battery Or Mains), Diesel, Petrol, Fuel Gas	electric	electric	electric	
1.4	Type Of Operation: Hand, Pedestrian, Standing, Seated, Order-Picker	seated	seated	seated	
1.5	Load Capacity / Rated Load	Kg (Lb)	1500 (3000)	1800 (3500)	2000 (4000)
1.6	Load Center Distance	c mm (in)	500 (24)	500 (24)	500 (24)
1.8	Load Distance, Center Of Drive Axle To Fork	x mm (in)	380 (14.96)	380 (14.96)	380 (14.96)
1.9	Wheelbase	y mm (in)	1345 (53.0)	1430 (56.30)	1430 (56.30)
WEIGHT					
2.1	Service Weight	kg (lb)	3118 (6874)	3407 (7511)	3542 (7809)
2.2	Axle Loading, Loaded Front / Rear	kg (lb)	4129/489 (8842/1032)	4642/565 (9748/1263)	4956/586 (10572/1237)
2.3	Axle Loading, Unloaded Front / Rear	kg (lb)	1654/1464 (3646/3228)	1741/1666 (3838/3673)	1725/1817 (3804/4005)
TIRES, CHASSIS					
3.1	Tires : Solid Rubber, Superelastic, Pneumatic, Polyurethane		SE	SE	SE
3.2	Tire Size, Front		18x7-8	200/50-10	200/50-10
3.3	Tire Size, Rear		15x4.5-8	15x4.5-8	15x4.5-8
3.5	Wheels, Number Front / Rear (X = Driven Wheels)		2x/2	2x/2	2x/2
3.6	Tread, Front	mm (in)	895 (35.2)	905 (35.6)	905 (35.6)
3.7	Tread, Rear	mm (in)	184 (7.24)	184 (7.24)	184 (7.24)
DIMENSIONS					
4.1	Tilt Of Mast/Fork Carriage Forward/Backward	degree	5/7	5/7	5/7
4.2	Height, Mast Lowered	h1 mm (in)	2120 (83.5)	2120 (83.5)	2120 (83.5)
4.3	Free Lift	h2 mm (in)	40 (1.5)	40 (1.5)	40 (1.5)
4.4	Lift Height	h3 mm (in)	3330 (131.10)	3330 (131.10)	3330 (131.10)
4.5	Height, Mast Extended	h4 mm (in)	4320 (170.07)	4320 (170.07)	4320 (170.07)
4.7	Height Of Overhead Guard (Cabin)	h5 mm (in)	2065 (81.29)	2065 (81.29)	2065 (81.29)
4.8	Seat Height / Stand Height Rel. To Sip	h7 mm (in)	1090 (42.91)	1090 (42.91)	1090 (42.91)
4.12	Coupling Height	h10 mm (in)	520 (20.5)	520 (20.5)	520 (20.5)
4.19	Overall Length	l1 mm (in)	2800 (110.24)	2890 (113.8)	2925 (114.56)
4.20	Length To Face Of Forks	l2 mm (in)	1900 (78.35)	1990 (78.3)	2025 (79.72)
4.21	Overall Width	b1 mm (in)	1074 (42.28)	1105 (43.50)	1105 (43.50)
4.22	Fork Dimensions	s x e x l mm (in)	40x100x900 (1.6x4x35.4)	40x100x900 (1.6x4x35.4)	40x100x900 (1.6x4x35.4)
4.23	Fork Carriage Iso 2328, Class / Type A, B		2A	2A	2A
4.24	Fork-Carriage Width	b3 mm (in)	1006 (39.60)	1006 (39.60)	1006 (39.60)
4.31	Ground Clearance, Below Mast, Loaded	m1 mm (in)	89 (3.50)	89 (3.50)	89 (3.50)
4.32	Ground Clearance, Center Of Wheelbase	m2 mm (in)	95 (3.74)	95 (3.74)	95 (3.74)
4.33	Aisle Width For Pallets 1000 X 1200 Crossways (L X W)	Ast mm (in)	3226 (127.00)	3316 (130.55)	3351 (131.92)
4.34	Aisle Width Of Pallets 800 X 1200 Crossways (W X L)	Ast mm (in)	3350 (131.88)	3440 (135.43)	3475 (136.81)
4.35	Turning Radius	Wa mm (in)	1540 (60.62)	1630 (64.17)	1660 (65.35)

PERFORMANCE DATA					
5.1	Travel Speed, Loaded / Unloaded	km/h (mph)	16/16 (9.9/9.9)	16/16 (9.9/9.9)	16/16 (9.9/9.9)
5.2	Lift Speed, Loaded / Unloaded	mm/s (ft/min)	400/550 (78.7/108.3)	400/550 (78.7/108.3)	400/550 (78.7/108.3)
5.3	Lowering Speed, Loaded / Unloaded	mm/s (ft/min)	550/450 (108.3/88.6)	550/450 (108.3/88.6)	550/450 (108.3/88.6)
5.6	Max. Drawbar Pull, Loaded / Unloaded	N (lb)	15102/14759 (3395/3318)	15190/14710 (3415/3306)	14367/14043 (3229.7/3156)
5.8	Max. Gradeability, Loaded / Unloaded	%	29.5/-	27.5/-	24.5/-
5.10	Service Brake		hydr.	hydr.	hydr.
ELECTRIC-MOTOR					
6.1	Drive Motor Rating S2 60 Min	kW (hp)	5.4x2 (7.3x2)	5.4x2 (7.3x2)	5.4x2 (7.3x2)
6.2	Lift Motor Rating At S3 15%	kW (hp)	14.9 (20.3)	14.9 (20.3)	14.9 (20.3)
6.4	Battery Voltage, Nominal Capacity K5	V/Ah	48/440	48/510	48/510
6.5	Battery Weight (Min.)	Kg (lb)	780 (1742)	950 (2094)	950 (2094)
6.7	Battery Compartment Dimensions L/W/H	mm (in)	983/553/650 (38.7/21.8/25.6)	983/638/650 (38.7/25.1/27.6)	983/638/650 (38.7/25.1/27.6)
ADDITION DATA					
8.1	Type Of Drive Control	AC	AC	AC	AC
8.2	Operating Pressure, System / Attachments	bar (psi)	190/130 (2755/1885)	190/130 (2755/1885)	190/130 (2755/1885)
8.3	Oil Volume For Attachments	LPM	20	20	20

Dimension

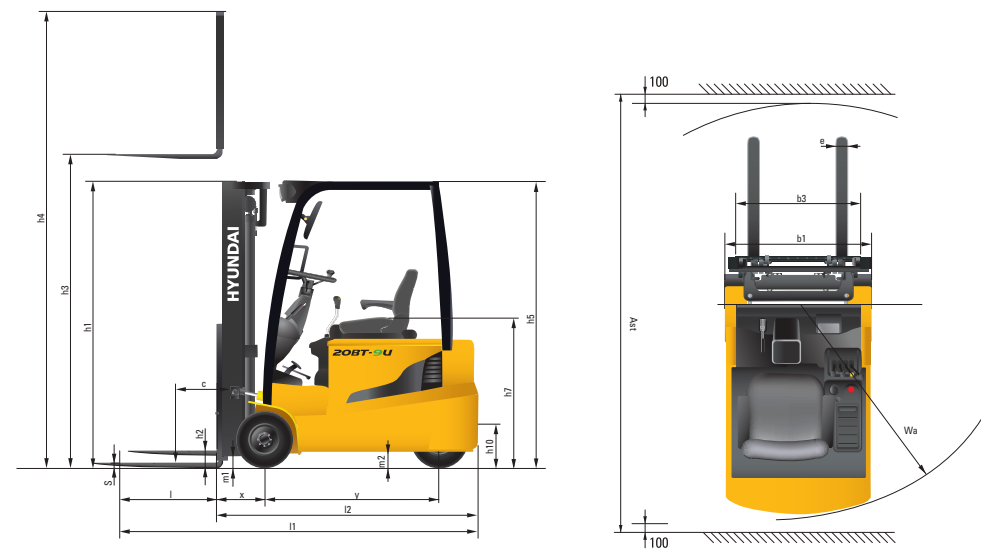

* All specifications in this catalog are subject to change according to the optional items.

